

Attention, Read all instruction and understand all warnings before install or using this product

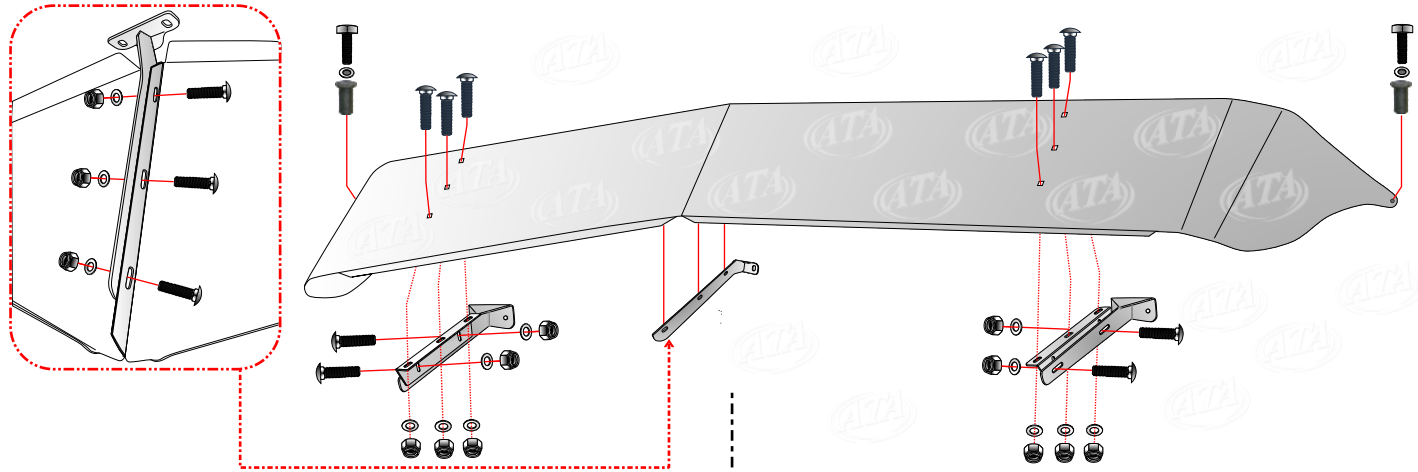

1 REMOVE VISOR



1. Remove the original visor and keep the brackets on the truck.

2 PREPARE YOUR WORK AREA

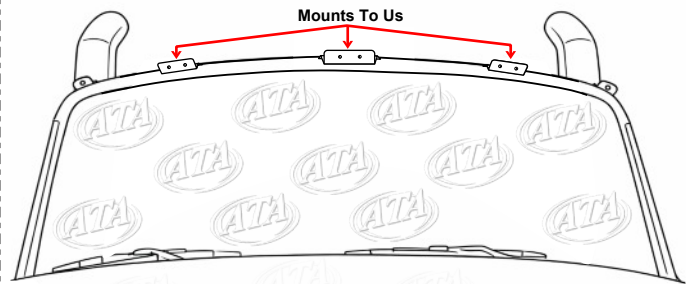

1. Use the painters tape to cover the side of the areas that will get scratched and where you'll have to drill.

Notes

- Use Safety glasses when using tools or working under vehicle
- Perform all work on dry level ground.
- Insure vehicles parking break is engaged and wheels are chocked.
- Due to the size and weight of the product, more then one person is Required for lifting and installing this product.



Tools Required

✓		Drill	✓		Grinding Disc	✓		Safety Glasses
✓		½ Drill Bit	✓		Extension Cord	✓		Glass Cleaner & Micro fiber cloth
✓		Wrench Kit / Small Sizes	✓		Ladder	✓		Ratchet Set
✓		Tape Measure	✓		Philips Screw Driver Set	✓		Gloves
✓		Blue Tape	✓		Grinder	✓		
✓		Black Marker						

3 INSTALL BRACKET

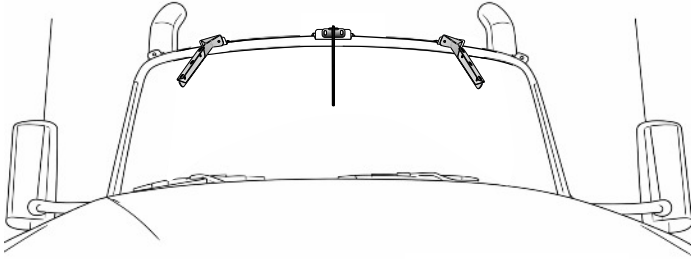

Note: DO NOT LEAN ON GLASS, it will break

1. Place brackets in there designated areas. Tighten the bolts.

4 ALIGN YOUR BRACKET

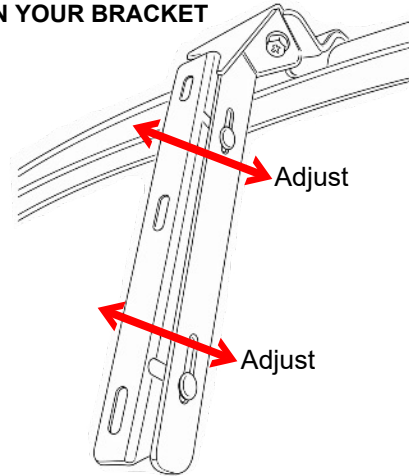

1. Adjust the bracket to desired height

5 MARK SIDE HOLE

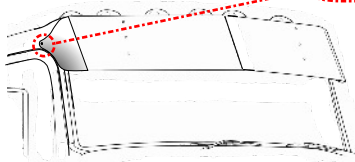
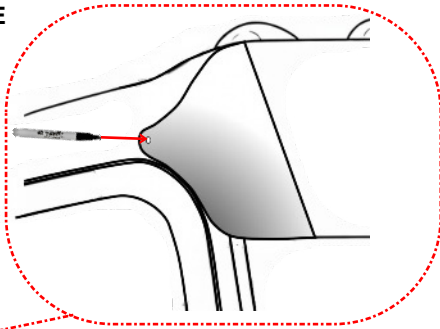

1. Put the visor together, Don't remove plastic.
2. Hand tighten visor to brackets and place on truck.
3. Tighten brackets fully and mark side holes to be drilled.

6 DRILL SIDE HOLE

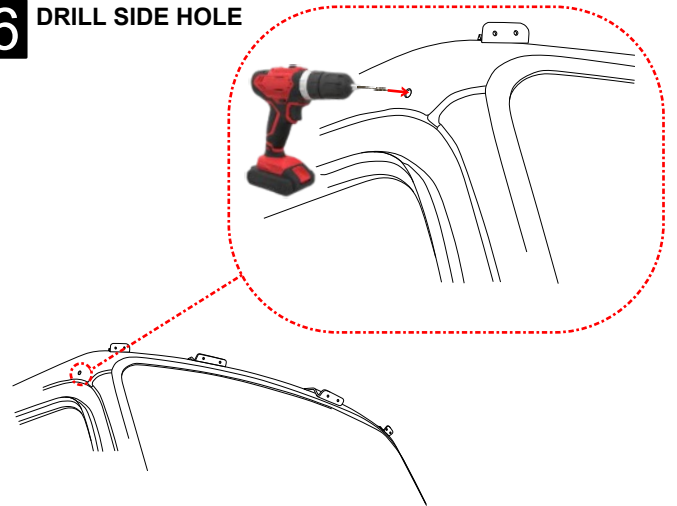

1. Remove visor
2. Drill the hole out with a stopper.

7 TIGHTEN VISOR

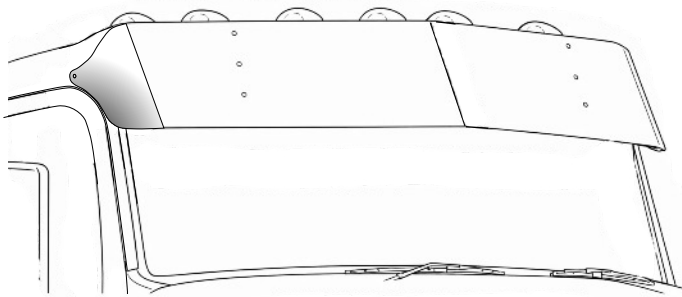

1. Remove plastic from around the visor holes only, not the whole thing.
2. Place visor on truck and tighten all bolts.

8 FINAL CHECK & CLEAN

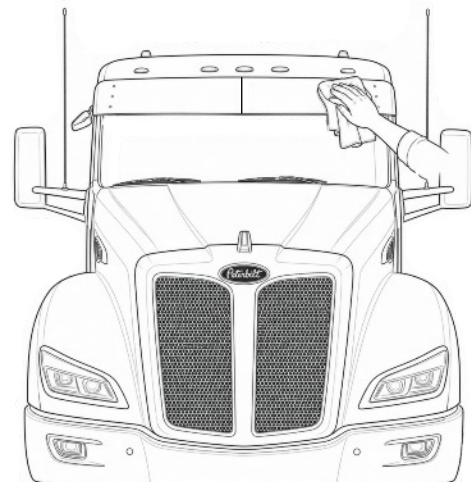

1. Remove plastic
2. Clean off any finger marks