

BP -5042, 5043

Step 1

Remove sleeper liner enough to be able to tighten the screws for the brackets on top & on the back.

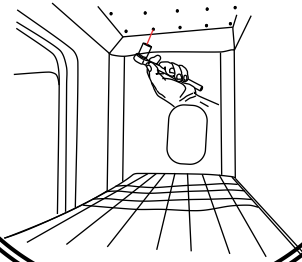

Step 2

After the liner is down, mark the holes from the top and drill them out caustically.

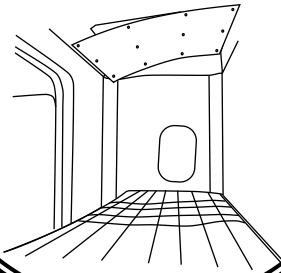

Step 3

Place the piece on top and tighten the nuts from the out side and the screw from the inside.

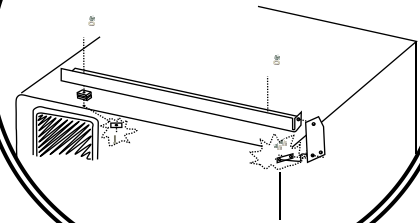

Step 4

Place the turbo wing on top & tighten the front of the turbo wing to the bracket & the back to the bar bracket then to the wing.

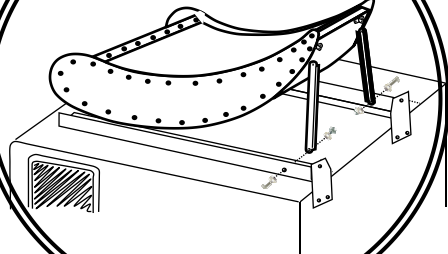

Step 5

You are finished! Remove plastic off the wing & clean with windex.

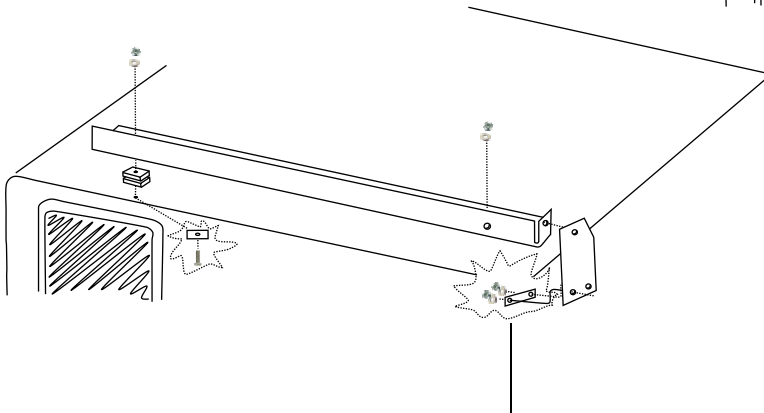
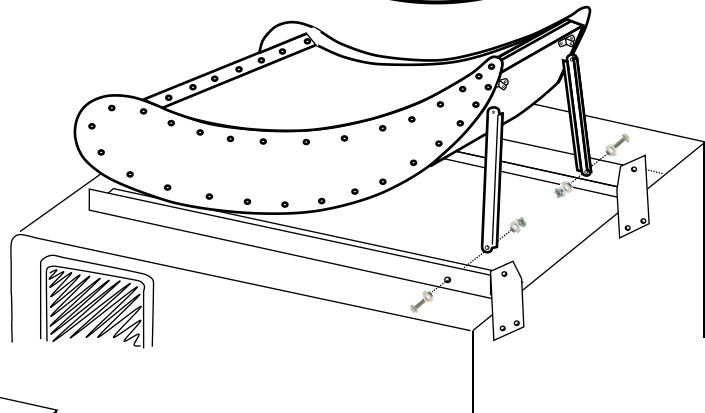
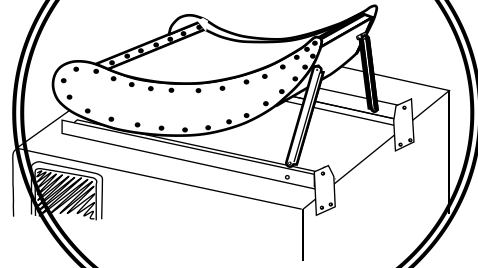

Notes

- Use silicone or something similar to patch any exposed holes once installation is completed.
- Drill cautiously to avoid puncturing the cabs interior.
- Do not use self drilling screws. Will not hold well.

Bolt Kit

	QTY: 10	Hex Head	3/8 - 20 x 1 1/4
	QTY: 2	Hex Head	3/8 - 20 x 1"
	QTY: 2	Hex Head	3/8 - 20 x 3/2
	QTY: 14	Nylon Hex Nuts	3/8
	QTY: 4	14G back plate	1 1/2 x 6"
	QTY: 46	Flat Washer	18-8 1/4 x 1/2
	QTY: 4	Plastic Flat Washers	18-8 1/4 x 1/2
	QTY: 2	S. S. Square Plate	2" x 3 3/4
	QTY: 4	SOF Plastic	2" x 3 3/4
	QTY: 4	SOF Plastic	1 1/2 x 6"
	QTY: 2	11 Gauge Support Brackets	2 1/4 x 14 1/16
	QTY: 1	11 Gauge Left Sleeper Mounts	12 1/2 x 6"
	QTY: 1	11 Gauge Right Sleeper Mounts	12 1/2 x 6"
	QTY: 4	11 Gauge Wing Connector	1 1/2 x 6"
	QTY: 4	14 Gauge Wing Connector	1 1/2 x 6"
	QTY: 1	11 Gauge Left Height Adjuster Support	33 1/2 x 3"
	QTY: 1	11 Gauge Right Height Adjuster Support	33 1/2 x 3"