

# The Pre-Trip Inspection Tool

Doing a quality pre-trip, post-trip, DOT, or preventative maintenance inspection has never been easier!! A tool every driver, technician, and maintenance manager should have.

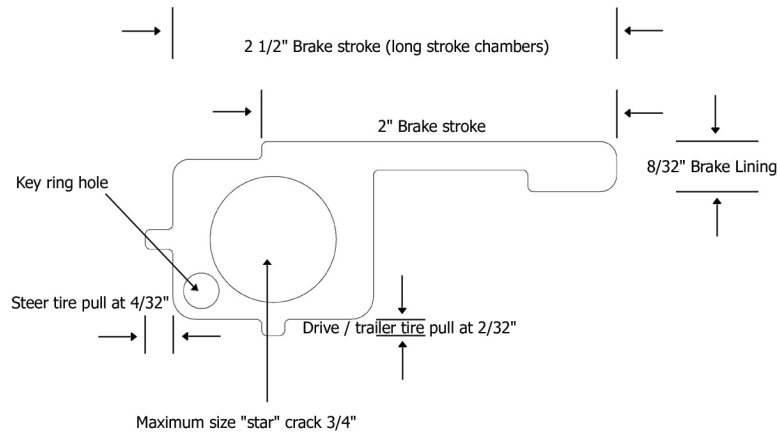

1. Checks tire depths instantly. No measuring device necessary. The "Pre-Trip Inspection Tool" can be custom made to company pull points. Simply insert the part of the tool designated for the tire being inspected. Studies have shown that a tire below 6/32" becomes much more vulnerable to pick up road debris.



2. Checks brake lining thickness quickly. Just insert the long end of the "Pre-Trip Inspection Tool" in between the drum and shoe table between the two linings. CVSA out of service criteria is 8/32" .

